



INSTALLATION INSTRUCTIONS

Accessory
FRONT LOWER TRIM
P/N 08P46-T0A-100

Application
2014 CR-V

Publications No.
All 50016

Issue Date
JULY 2013

PARTS LIST

Front lower trim

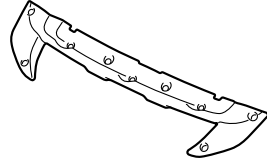

4 Bolts



3 Small well nuts

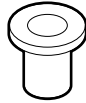

4 Large well nuts



3 Washer-screws



2 Clips

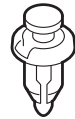

TOOL AND SUPPLIES REQUIRED

Phillips screwdriver

Hex wrench

Drill

3 mm, 5 mm, 8 mm, and 13 mm Drill bits

Pushpin

Eye protection (face shield, safety goggles, etc.)

Ruler

Tape

Torque wrench

Rigid rack

The following tool is available through the Honda Tool and Equipment Program. On the iN, click on: Service > Service Bay > Tool and Equipment Program, then enter the number under "Search." Or call 888-424-6857.

- Plastic Trim Tool (T/N SILTRIMTL10)

Illustration of the Front Lower Trim Installed on the Vehicle

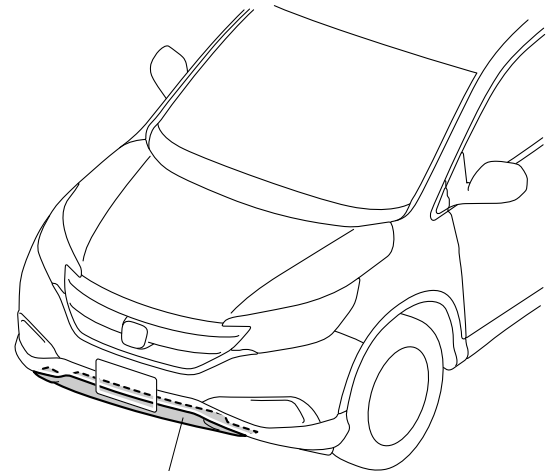

FRONT LOWER TRIM

INSTALLATION

Customer Information: The information in this installation instruction is intended for use only by skilled technicians who have the proper tools, equipment, and training to correctly and safely add equipment to your vehicle. These procedures should not be attempted by “do-it-yourselfers.”

NOTE: Be careful not to damage the paint finish.

1. With the vehicle on a lift, remove the two center clips from the front bumper.

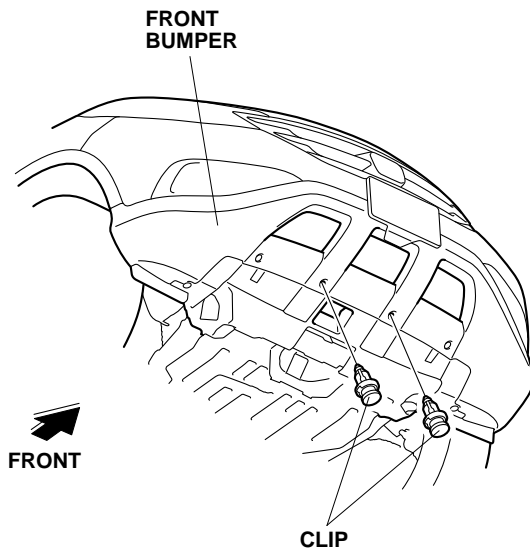

2. Position the front lower trim on the front bumper, and install the front lower trim with the two clips removed in step 1.

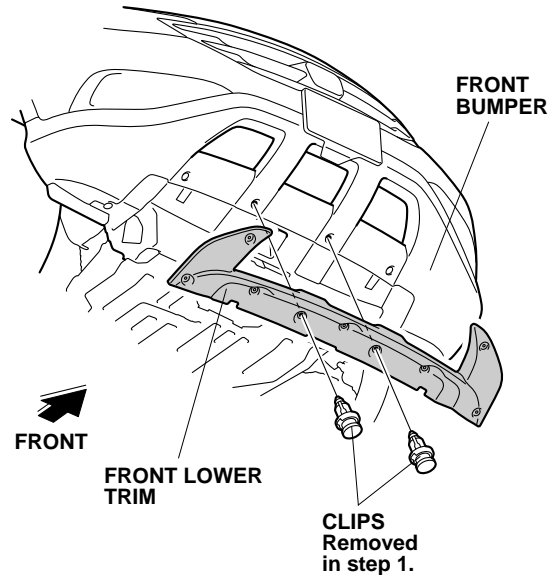

3. Using a pushpin, pierce the front bumper through the seven holes in the front lower trim.

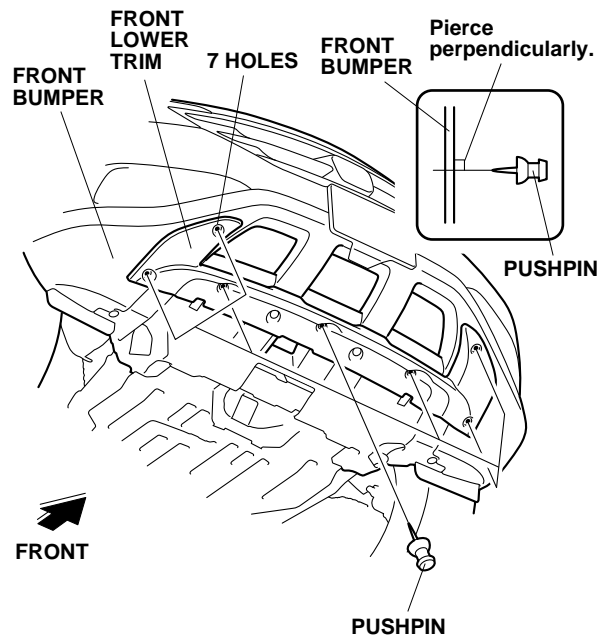

4. Remove the front lower trim (two clips).

- While wearing eye protection, drill the four outboard pierced marks to 13 mm. First drill with a 3 mm drill bit, then with a 5 mm drill bit, then with an 8 mm, and finish with a 13 mm drill bit.
 - Wrap tape around each drill bit 10 mm away from the tip or use a drill stop.
 - Remove all burrs.

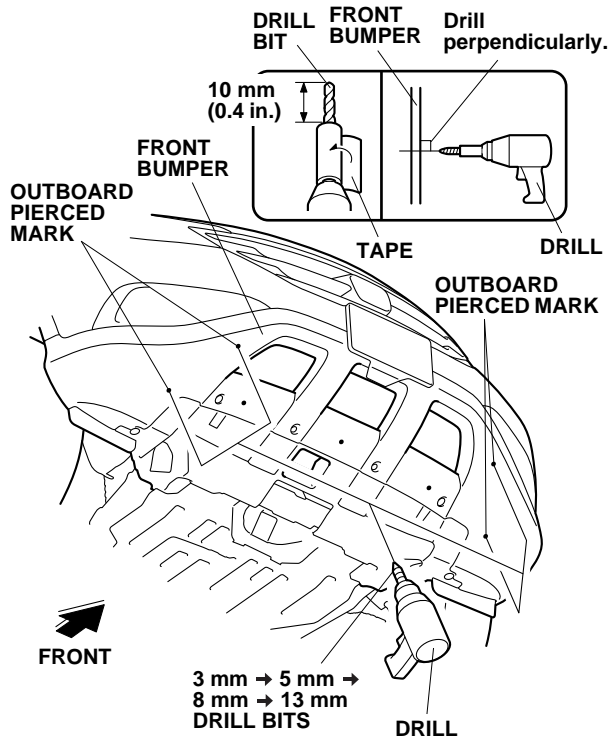

- While wearing eye protection, drill the three inboard pierced marks to 8 mm. First drill with a 3 mm drill bit, then with a 5 mm drill bit, and finish with an 8 mm drill bit.
 - Wrap tape around each drill bit 10 mm away from the tip or use a drill stop.
 - Remove all burrs.

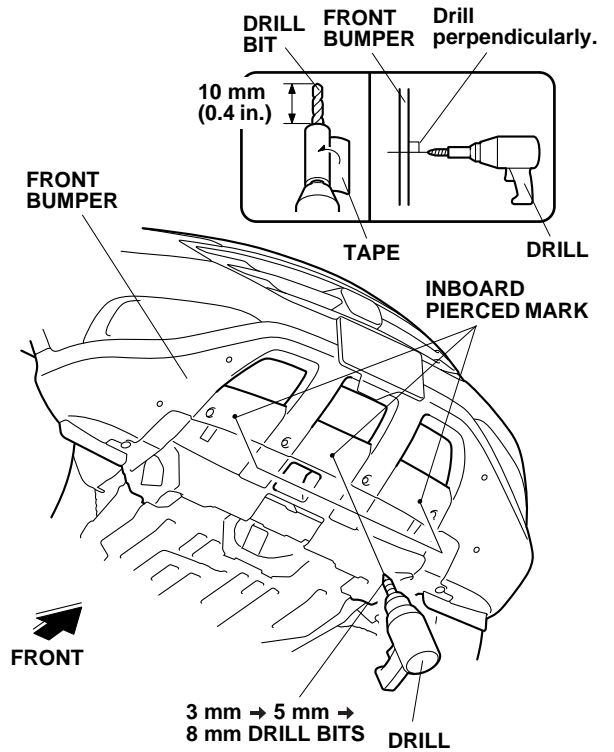

- Install one large well nut into each 13 mm outboard hole. Install one small well nut into each 8 mm inboard hole.

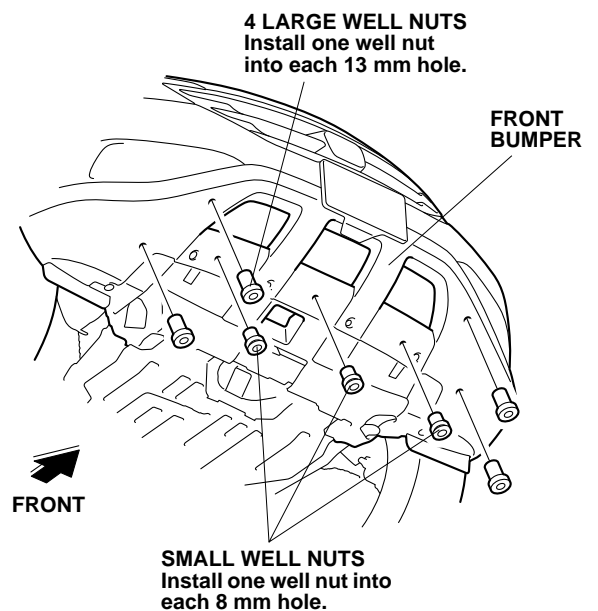

- While wearing eye protection, drill the inboard holes in the front lower trim using a 5 mm drill bit. Remove all burrs. Do not drill the two clip installation holes.

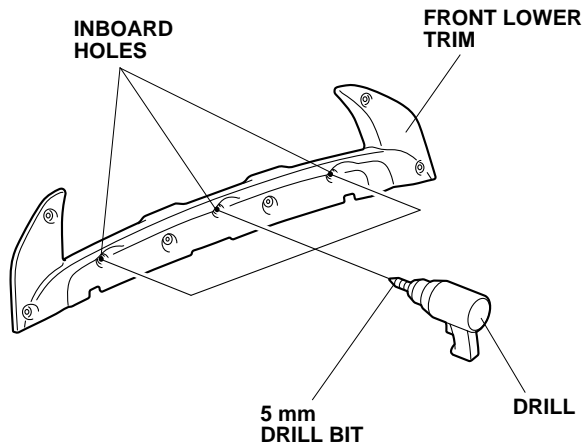

- While wearing eye protection, drill the four outboard holes to 8 mm. First drill with a 5 mm drill bit, and finish with an 8 mm drill bit. Remove all burrs.

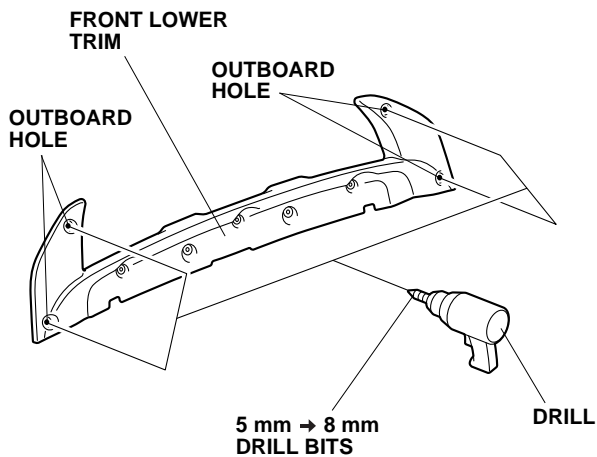

- Position the front lower trim on the front bumper, and install it with two new clips. Make sure the rubber molding is not twisted or rolled under the front lower trim.

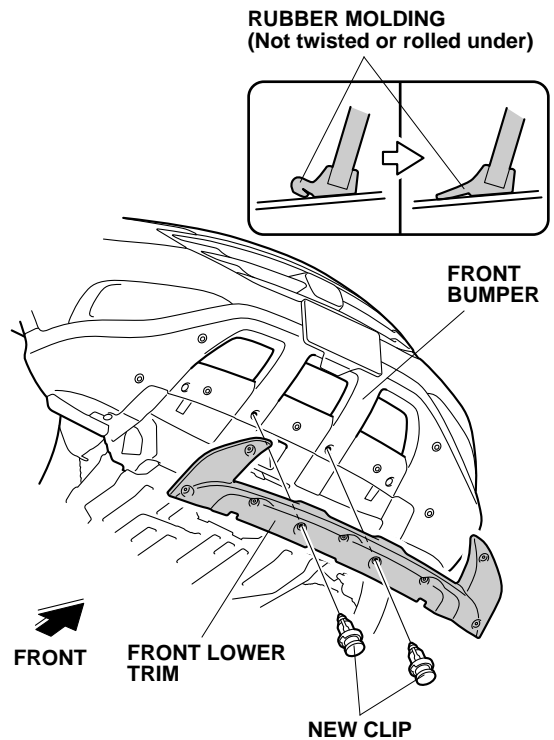

- Install one washer-screw into each 8 mm well nut in the order 1 → 2. Torque the washer-screws to 0.4 N·m (0.3 lbf·ft).

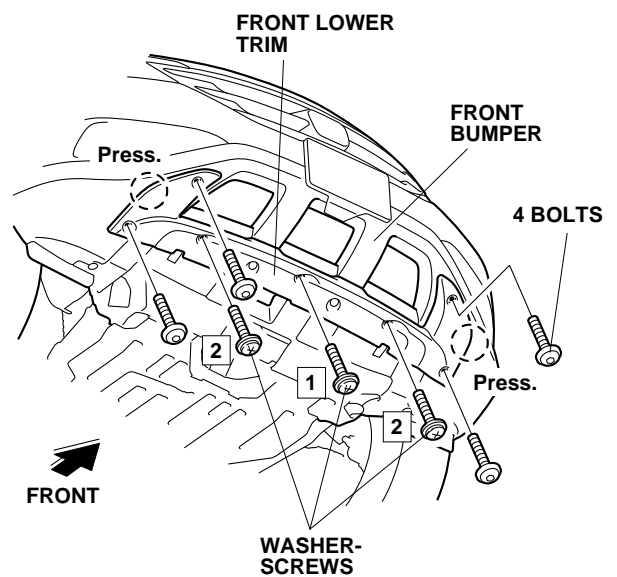

- Install one bolt into each outboard 13 mm well nut and torque each bolt to 1.0 N·m (0.7 lbf·ft). Press the front lower trim against the front bumper when tightening the bolts on each side.